

# The Patchwork Promise: Creating a Better Future



Ann Quiroz Gates

Associate Vice-President for Research

The University of Texas at El Paso



For **innovation** to happen depends as much on **collective difference** as on aggregate ability. If people think alike, then no matter how smart they are they most likely will get stuck at the same locally optimal solutions.

**Finding new and better solutions, innovating, requires thinking differently.**

Scott E. Page

Professor of Complex Systems, Political Science, Economics

University of Michigan

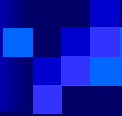

**Computational  
Sciences and  
Engineering**

**University of  
Texas at  
Austin**

**Imaging  
Physics**

**Biomedical  
Engineering**

**MD Anderson  
Cancer Center**

# **IMPROVING LASER TREATMENT OF CANCER**

**ACKNOWLEDGEMENT: DR. J. TINSLEY ODEN, UT AUSTIN**



# Dynamic Data Driven System for Laser Treatment of Cancer

- Interaction between computer simulation of bioheat transfer processes and thermal imaging equipment to enhance thermal therapies
- Real-time finite element solution of the problems of calibration, optimal heat source control, and goal-oriented error estimation

# Innovation

- Real time control of surgical procedure
- Allows a physician to use temperature imaging to plan, treat, and guide therapy.
- Use CI to transfer MRI data
- Run modeling & simulation at UT Austin and return info to physician at MD Anderson

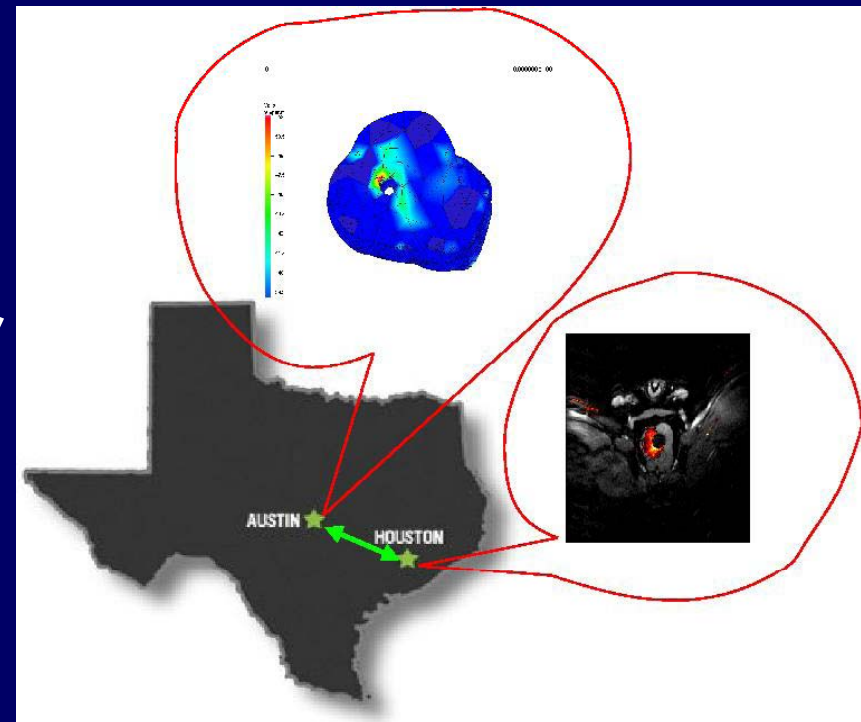



# Challenges

- Complexity of project
  - More than any one person needed to understand-- requires a team
- Communication
  - Need to translate work to assist others in their understanding
  - New understanding arises from the explanations
- Cross-disciplinary knowledge



# Lessons: Success of Project

- Willingness of all to collaborate and educate members of the team
- Positive attitudes
- Acceptance of working with people who are different

Everyone knows everything about the project, but no one possesses the detail of all parts.

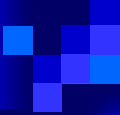

<b>Robert Full Professor Berkeley</b>	<b>Arts</b>	<b>Science</b>	<b>Diverse Undergrads</b>
<b>Center Inter- Disciplinary Biological- Inspiration, Ed &amp; Research</b>	<b>Humanities</b>	<b>Engineering</b>	<b>Diverse Grads</b>

# **EDUCATIONAL MODEL ENCOURAGES INNOVATION**

**ACKNOWLEDGEMENT: DR. ROBERT FULL, UC BERKELEY**

# Biomotion Course

DEPARTMENT OF INTEGRATIVE BIOLOGY

**IB 32**

Spring 2001

**BIOMOTION**  
Solve The Mysteries Of Motion

WITH  
Dr. ROBERT J. FULL

DESIGN ROBOT EXPLORERS FOR NASA  
USING MODELING TOY KITS

COMPUTER ANIMATION

ARTIFICIAL MUSCLES

DESIGN

PROSTHESIS

ANIMATRONICS

SPORTS

- Taught for over ten years using mutualistic teaming
- Involves students from STEM , art, humanities
- Challenged with design robot inspired by nature
- Resulted in original discoveries in biomotion

# Innovation: Self-Stabilizing Robot

- Cockroaches have springy legs and appear to be self-stabilizing
- Control built into the body and legs
- *Pixar's question:* Why model just “up and down” motion if insects move in horizontal plane?
- UG Kubow created horizontal plane mathematical model that self-stabilizes.



# Innovation: Gecko inspires waterproof bandage for surgical wounds and internal injuries



Rows of actual Gecko hairs

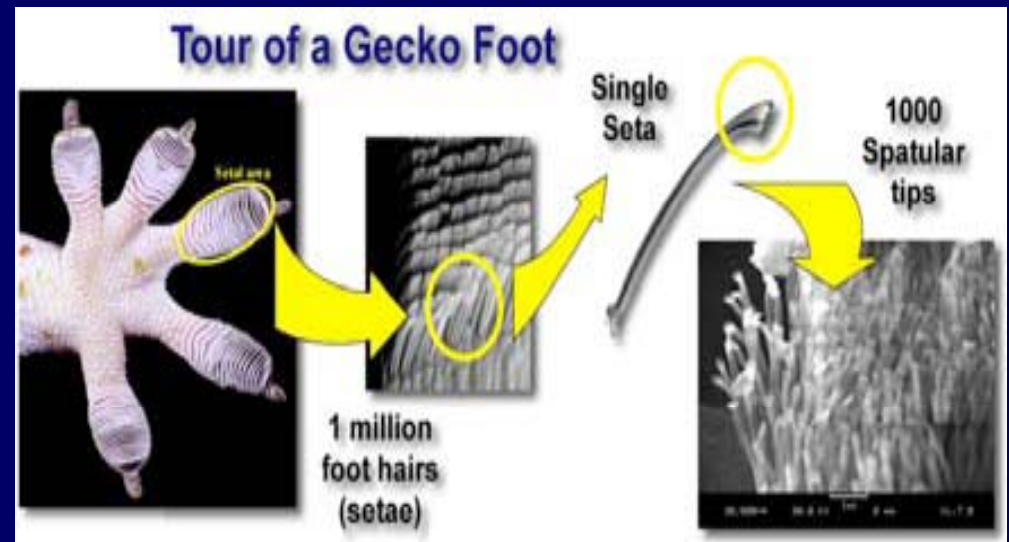



# Lessons on Interdisciplinary Research-based Education

- Challenge students with real problems that require inter-disciplinary solutions.
- Include diverse undergraduates, who can bring new concepts, approaches and tools to the classroom and lab.
- Develop tools of critical thinking in creative context to empower students for a lifetime.
- Give students the thrill of original discovery.



<b>Caroline Baillie</b>	<b>Cartoneros</b>	<b>Community members</b>	<b>Local business</b>
<b>Queens University Canada</b>	<b>NGOs</b>	<b>Governmental Organizations</b>	<b>Cooperatives</b>

# **WASTE FOR LIFE: REDUCING POVERTY**

**ACKNOWLEDGEMENT: DR. CAROLINE BAILLIE, QUEENS UNIVERSITY**

# Waste for Life Project Description

- Collaboration with cartoneros who collect recyclable garbage
- Goal: move collectors to manufacturers of recycled products
- Transfer knowledge of recycling and processing of composite materials



# Questions

- Could the cartoneros (cooperatives) make simple composite materials, given adequate training and equipment?
- What would be the fiber and the plastic?
- Was this a good direction to move in or should we leave this to the government?
- Would it be better to work on a project suggested by local non-governmental organizations (NGOs)?

# Innovation: Manufacturing and Recycling

- Developed and tested composites made from plastic bags and cardboard pulp
- Designed low-cost hotpress
- Designed ingenious products: chair, table, and venetian blinds



# Lessons

- Social impact is complicated
  - Need to understand the political landscape
  - Considerations of sustainability
- Understand the limits to the knowledge base
  - Need to frame the historical and political context of the current socioeconomic climate
  - Need to properly address the question of who benefits and who pays.
- Need for understanding of global issues

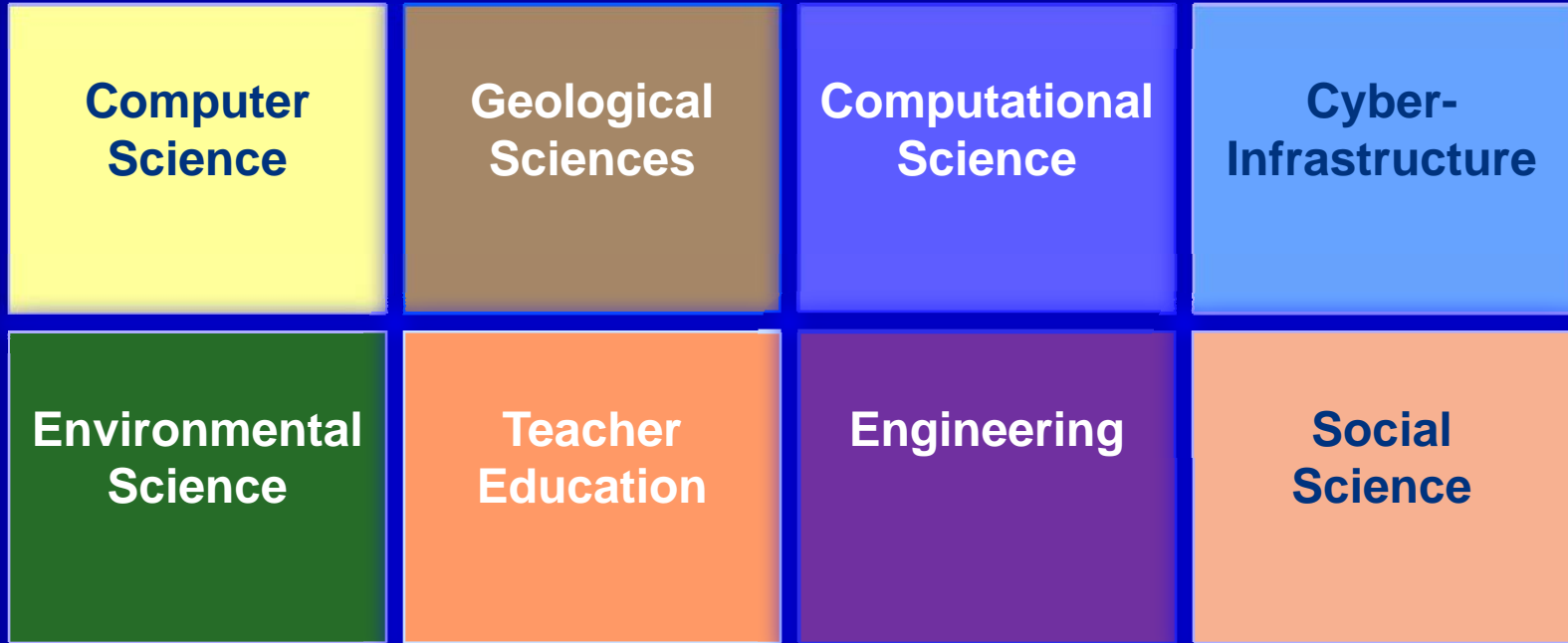

**UTEP'S CYBER-SHARE CENTER:  
SHARING RESOURCES TO ADVANCE  
SCIENCE AND EDUCATION**

# Cyberinfrastructure (Atkins, 2003)

**KNOWLEDGE ENVIRONMENTS for  
RESEARCH AND EDUCATION**  
(virtual community or e-science community)

**Customized for discipline and project-specific applications**

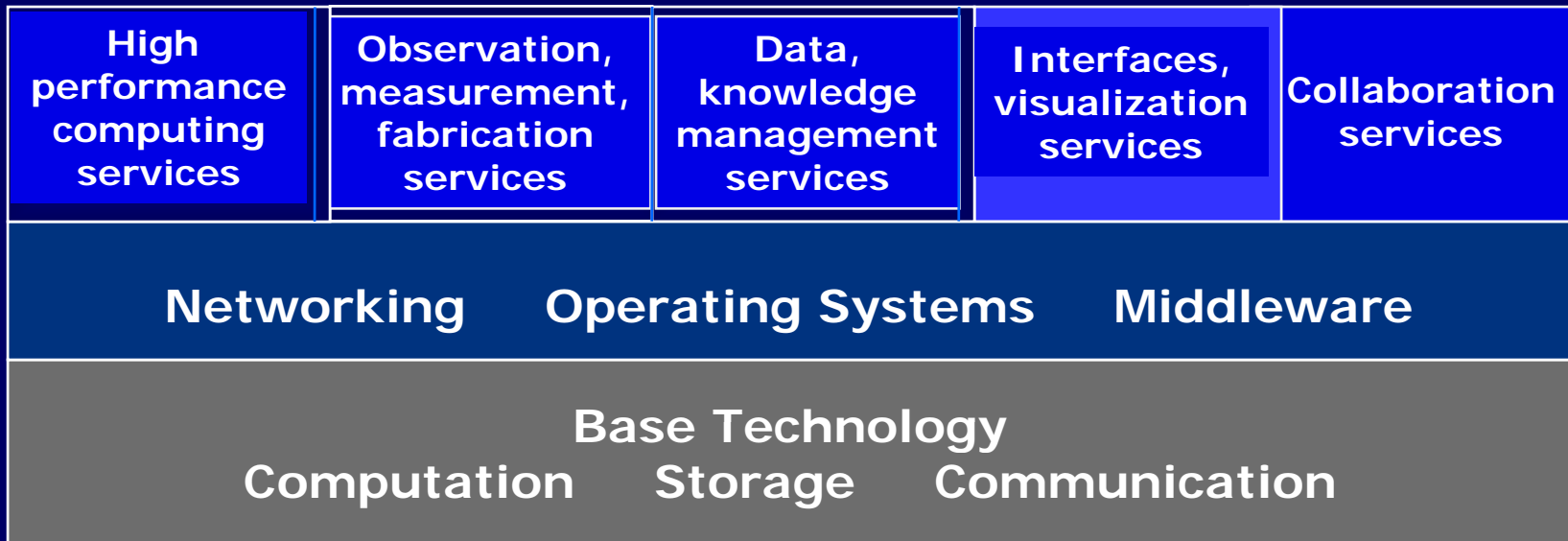



# Cyber-ShARE: Goals

- Support cross-disciplinary research in science, engineering, and technology
- Work with scientists, engineers, and educators to develop and share knowledge, resources, and tools
- Support scientists as they transition from locally held resources to resources available through network or portal
- Provide assurance that the resources are accurate, reliable and trustworthy

# CyberShARE Subprojects

CS

- The Quest to Understand and Trust Scientific Results

GEO

- Effective Development of 3-D Models of Earth Structure

ES

- Advancing the Utility of CI in Environmental Science



# Student Preparation

- Immerse in the disciplines with which they work
- Hold weekly interdisciplinary research meetings
- Register in courses in areas outside field of study
- Involve in field work

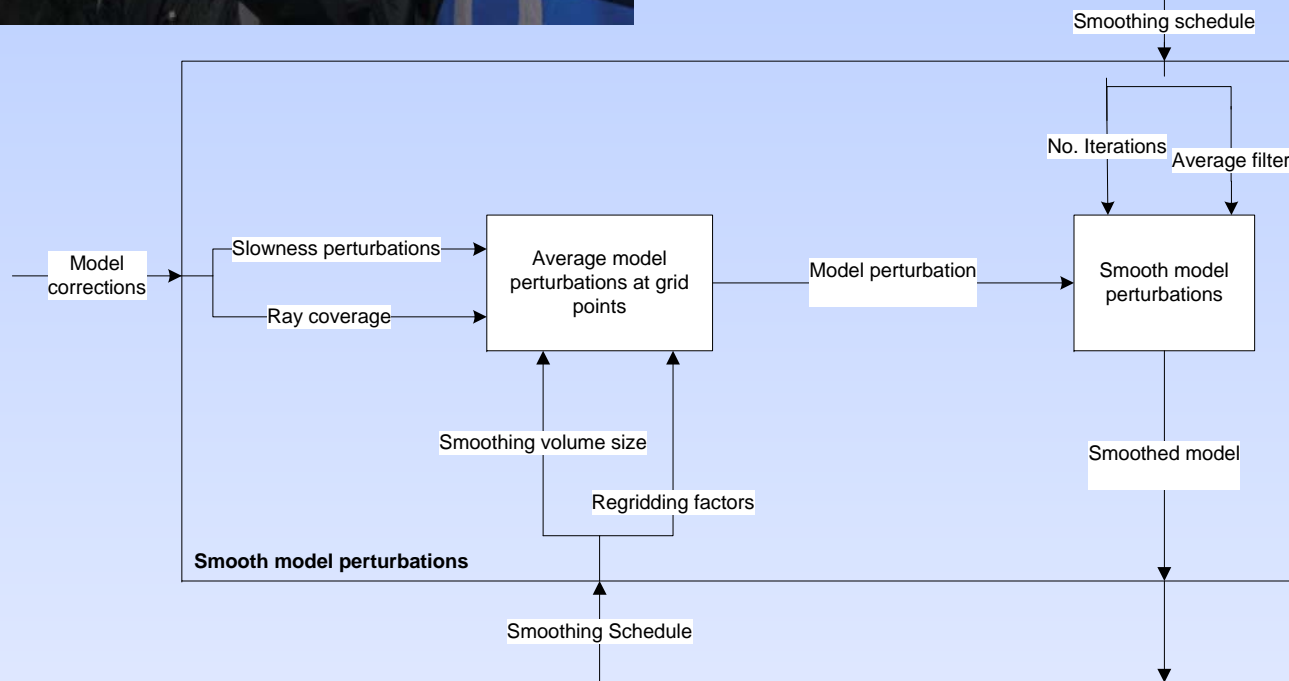
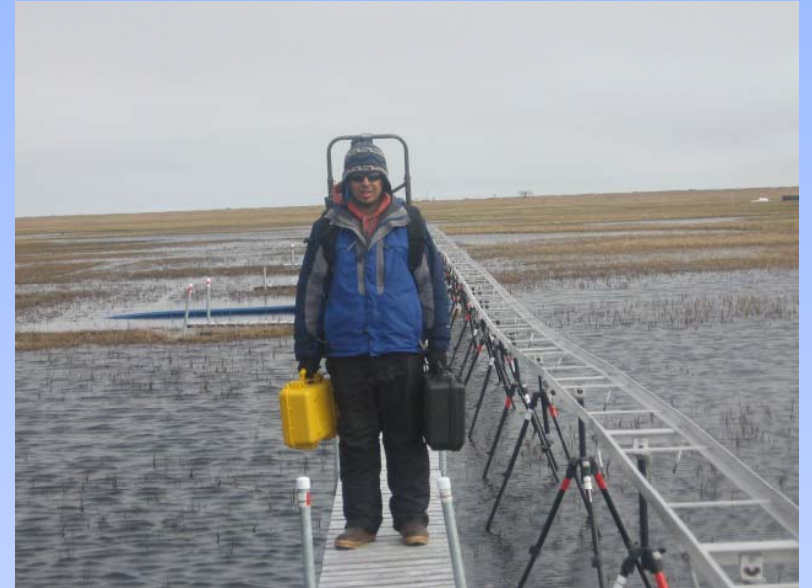

Workspace

Loaded Workflows

punch

holesanalysis

Data

- 1DModel
- 3DVelocityModel
  - smoothed3DModel
  - filter3DModel
- griddedTimeField
- shotpoints
- travelTimeResiduals
- rayCoverageArray

Method

- vel1d
- punch
- cover
- finddt
- tomosm
- duadd
- addc
- DataSwitch

Model-Based Workflow: <http://holesanalysis>

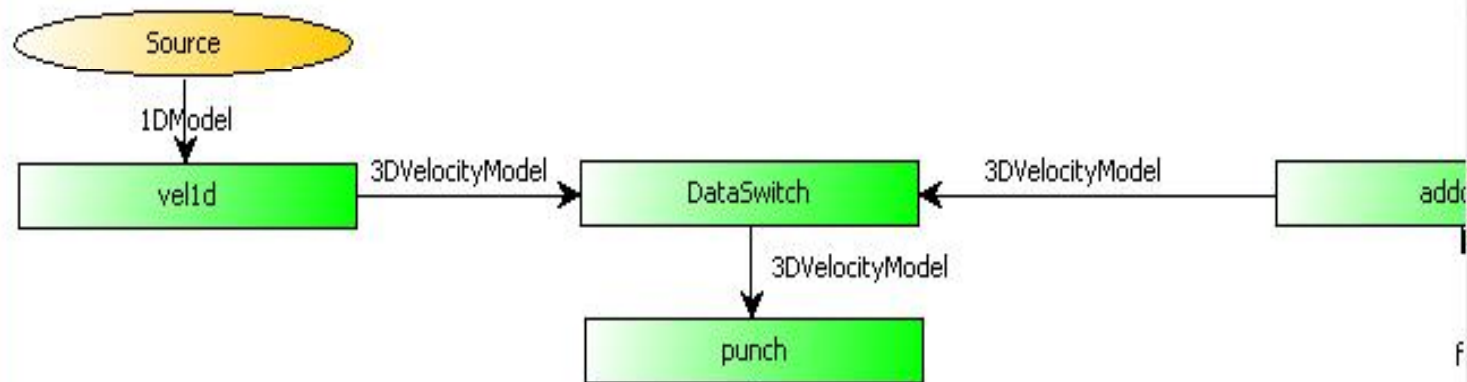



# Lessons on Interdisciplinary Projects

- Articulate benefits of collaboration
- Clarify differences in language
- Establish lines of communication
- Build trust and respect

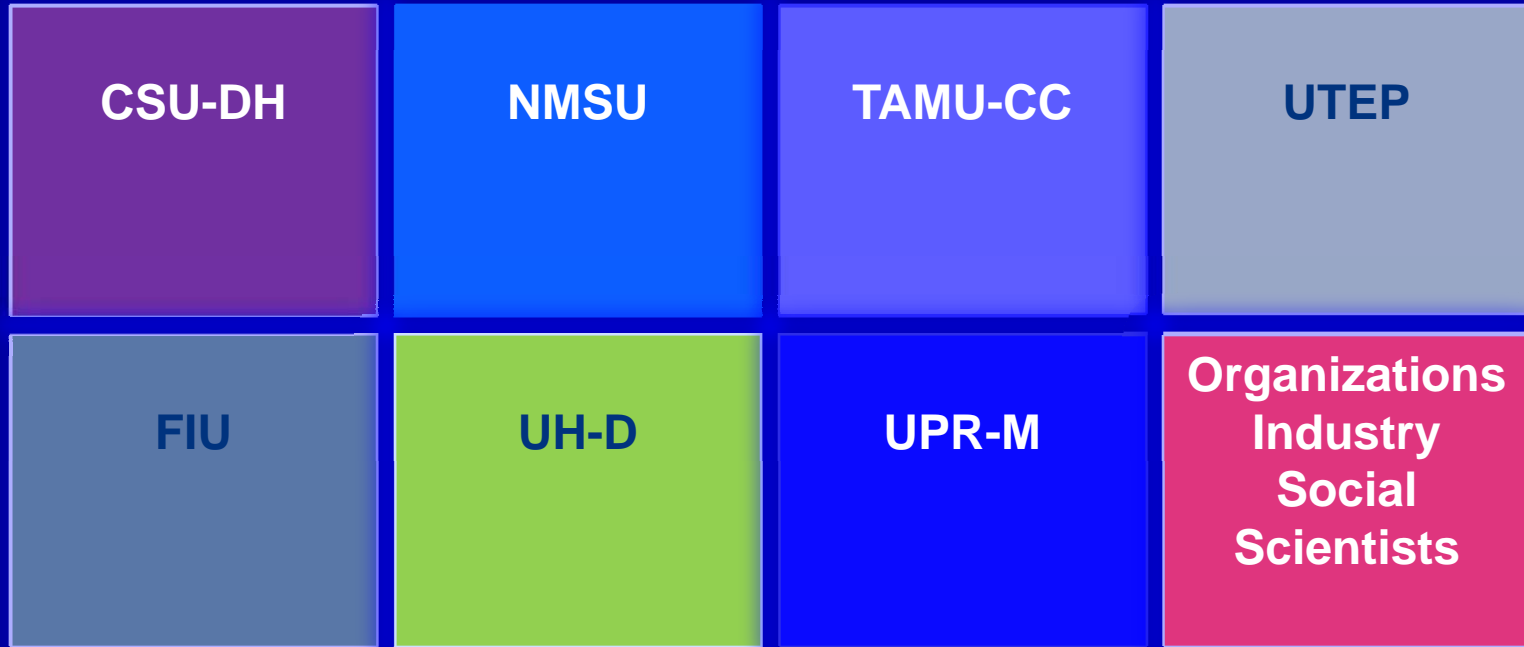

# CAHSI: RECRUITING, RETAINING, AND ADVANCING HISPANICS IN COMPUTING

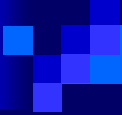

# Computing Alliance of Hispanic-Serving Institutions: Core Purpose

Create a **unified voice** by coordinating the strengths, resources, and concerns of HSIs and other groups committed to increasing the number of Hispanics in all computing areas.



# Collaborations

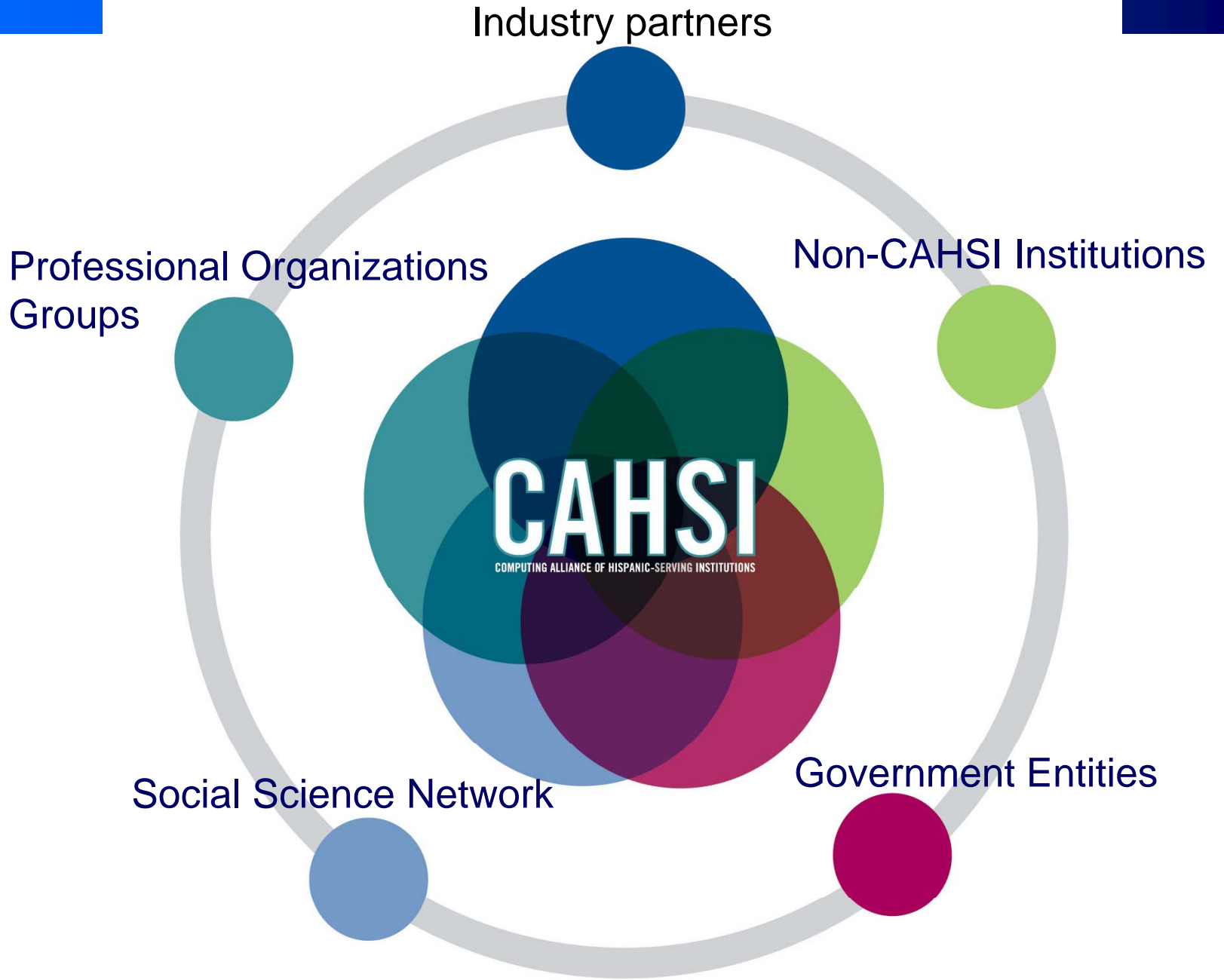

# Initiatives

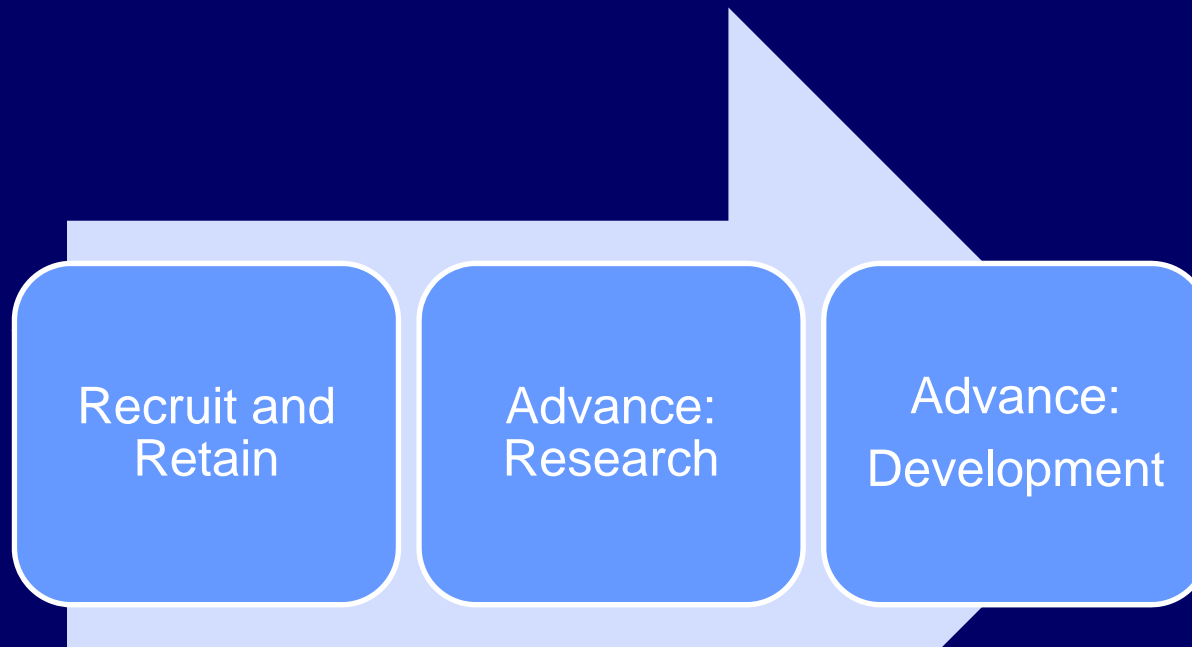

- **Advocates**
- **CSO**
- **PLTL**

- **ARG**
- **Course**
- **Posters**

- **Mentoring**
- **Workshops**
- **Lecture Series**



# Lessons

- Importance of working as a unified group
- Power of sharing
- Need to respect differences



# CLOSING REMARKS

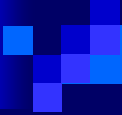

My projects arise as my response to life and to personal experiences. I want my work to initiate a discourse to encourage thoughtfulness and transformation within our communities.

I see my fabric and thread images cutting through biases and judgments.

Master Quilter Deidre Scherer on “Why quilting is so important.”



# CELEBRATE AND EMBRACE YOUR UNIQUENESS!

Contact:

[agates@utep.edu](mailto:agates@utep.edu)